

Mobile display stand for interactive white board for educational teaching purposes

Model #: IWB

iRover² - Short Throw Arm (Front View)

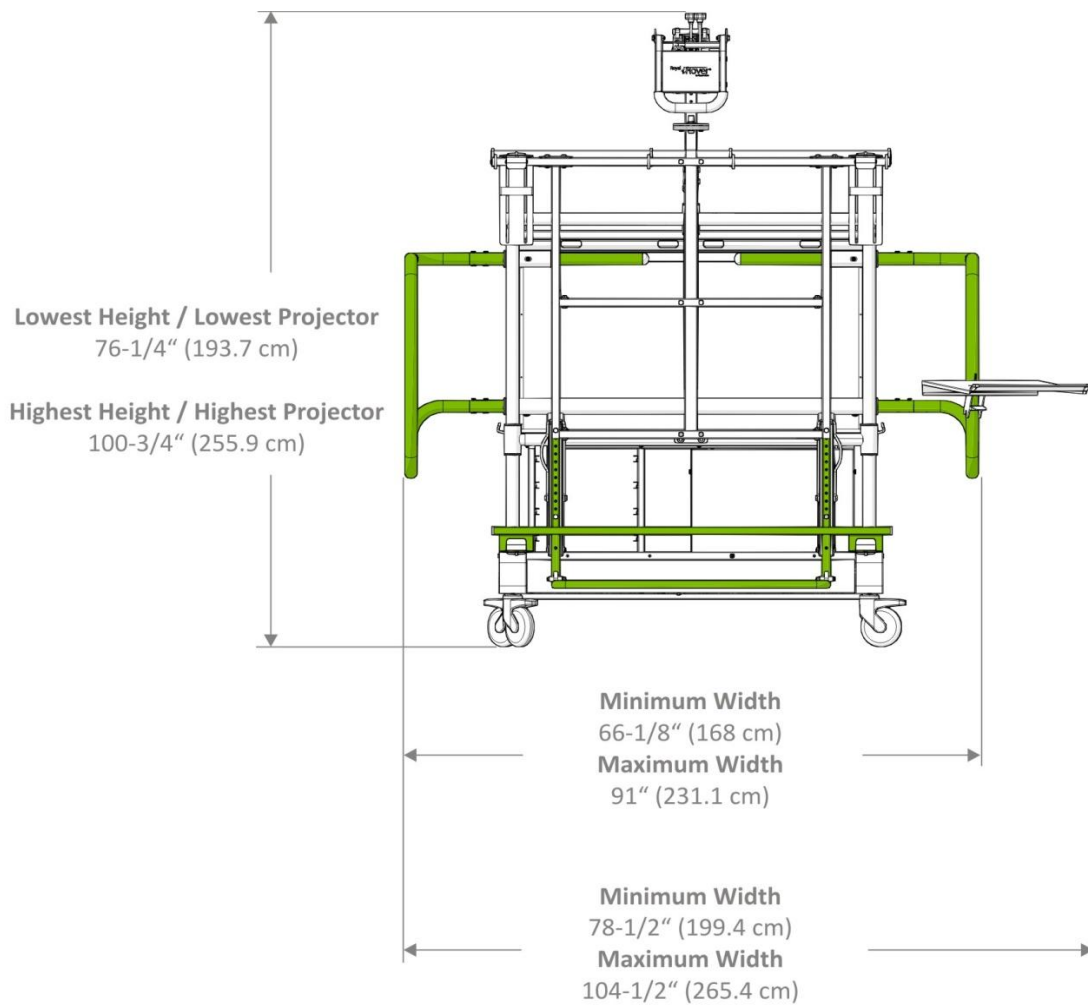

All dimensions +/- 1/8" (.32 cm). All weights +/- 2 lbs. (0.9 kg).

Mobile display stand for interactive white board for educational teaching purposes

Model #: IWB

iRover² - Short Throw Arm (Side View)

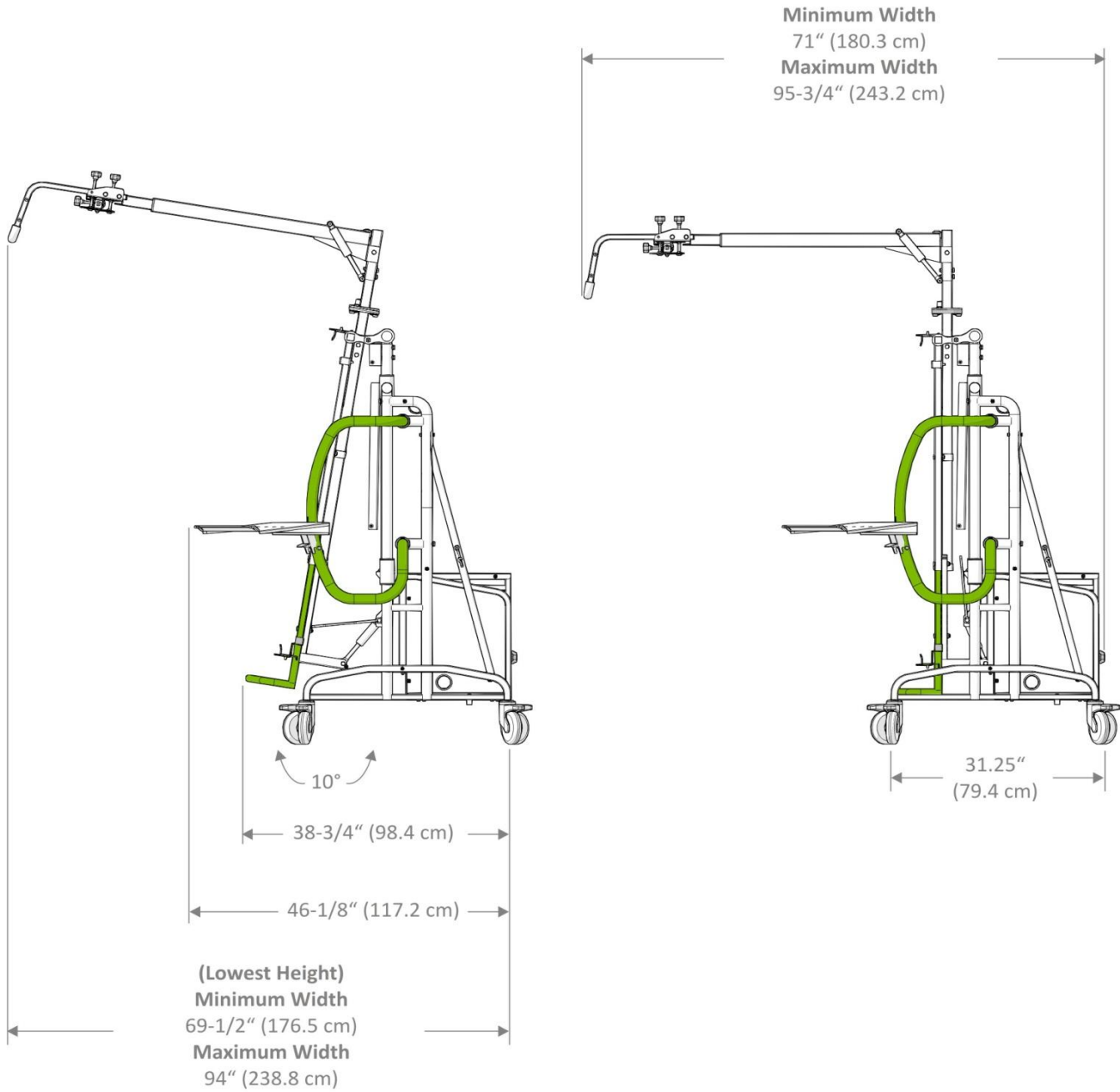

All dimensions +/- 1/8" (.32 cm). All weights +/- 2 lbs. (0.9 kg).



Mobile display stand for interactive white board for educational teaching purposes

Model #: IWB

Warranty:

Five-years limited frame/equipment warranty (excludes projectors and electrical cords, etc.).

iRover² Options:

Base Unit

The Base unit includes the Main Frame, Projector Arm, and Laptop Arm.

Premium Unit

The Premium unit includes all Base unit features plus - Lock Box, Tub Frame, and Rear Whiteboard.

Physical Specifications for Stand Only (Minimum Position):

Projector Short-Throw arm extended for use:

180.3 cm W x 193.7 cm H x 168 cm D (71"W x 76.25"H x 66.125"D)

Projector Short-Throw arm extended for use with the Frame Tilted Out:

176.5 cm W x 209.6 cm H x 168 cm D (69.5"W x 82.5"H x 66.125"D)

Projector Short-Throw arm folded to side for storage:

82 cm W x 193.7 cm H x 210.8 cm D (32.25"W x 76.25"H x 83"D)

Physical Specifications for Stand Only (Maximum Position):

Projector Short-Throw arm extended for use:

243.2 cm W x 255.9 cm H x 231.1 cm D (95.75"W x 100.75"H x 91"D)

Projector Short-Throw arm folded to side for storage:

82 cm W x 255.9 cm H x 274.3 cm D (32.25"W x 100.75"H x 108"D)

The Board Can not be tilted when in highest height position.



Mobile display stand for interactive white board for educational teaching purposes

Model #: IWB

Product Features:

Expandable Mounting Brackets:

Mount a range of different 4:3 or 16:10 sized boards on one frame using the adjustable board mounting brackets. Brackets clamp securely around 600 and 800 series SMARTBoard, Promethean, and Copernicus Dry Erase Boards, and feature rubber insulation to protect board's edges and minimize vibrations.

The board thickness allowance is from 3/4" (1.9 cm) up to 1-7/8" (4.8 cm).

Projector Arm (IWB-4):

Locking and adjustable mechanism allows arm to be easily moved with one hand. Rotates counter-clockwise, stops at 90 degree increments to move through doorways. Universal multimount plate supports a range of projectors. Check compatibility chart on Copernicus website for current supported projectors.

Lock Box (IWB-7):

Outer dimension measures 50.8 cm W x 48 cm H x 38.6 cm D (20" W x 18.875" H x 15.25" D), inside dimensions measures 38.8 cm W x 33.2 cm H x 36.2 cm D (15.25" W x 13" H x 14.25" D). Made of dent resistant metal and powder coat finish. Features 1/4 turn locking fastener with key(s) for security, and can accommodate CPU. Cable and vent holes are 4.8 cm H (1.875") on sides of box and on top.

Laptop Arm (IWB-LA):

Removable tray, when in use fits on the handle. Measures 41.9 cm W x 29.8 cm D (16.5" W x 11.75 D). Made of durable metal, with powder coated finish. When not in use hangs on to the side of the cart.

Tub Frame (IWB-9):

Measures 36.5 cm W x 48.3 cm H x 38.1 cm D (14.375" W x 19" H x 15" D). Holds 3 stubby tubbies and 1 open tubs. Made of durable metal with powder coat finish.

Mobility:

10 cm (4") twin swivel wheel, total lock brake; locks the swivel and the roll in two directions. Holds the unit securely in position. Brakes only on back two casters. Casters feature a pinch point free break.

Stability:

Wide leg base of 119.1 cm W x 76.2 cm D (46.875" W x 30" D) from leg to leg adds stability to unit. When moving, weight is transferred to lowest position (board, arm, etc), making it more stable and safe to move. Projector Arm locks into place when moving and laptop arm hangs on side of the cart.

Please ensure your iRover² is moved with two people.



Mobile display stand for interactive white board for educational teaching purposes

Model #: IWB

Cable Management / Wire Management:

All cables route down the back side of the iRover². A black plastic cable management channel on the back houses the VGA cable, to route it along the back of the unit to the laptop or computer source. Labelling tags are included to help you identify your different cables.

Rear Whiteboard (IWB-8):

Extra surface is provided for the teacher or student for small group activities or as a memo board. The board is magnetic and dry erase. The dimensions of the whiteboard are 103.5 cm W x 54.1 cm H (40.75" W x 21.25" H).

Power Specifications:

Seven outlet receptacle power bar included.

Accommodates 720 Joule energy rating to provide max protection for all your sensitive electronics, 48000A Surge Current.

12' power cord delivers safe AC power through a 14-gauge heavy-duty cord. Surge protector filters EMI/RFI.

Power bar Certifications - CSA/CE.



Mobile display stand for interactive white board for educational teaching purposes

Model #: IWB

Maximum Weight for Unit:

- Laptop Tray:** Recommended maximum weight of 20 lbs. (On Tray)
- Tub Frame:** Recommended maximum weight of 20 lbs. (On Top Shelf)
Recommended maximum weight of 5 lbs. (Each Stubby Tubby)
Recommended maximum weight of 10 lbs. (Each Open Tub)
- Lock Box:** Recommended maximum weight of 50 lbs. (In Box)
- Bottom Shelf (Base Unit):** Recommended maximum weight of 50 lbs. (On Top Shelf)

Estimated Carton Size & Weights:

	Part No.	Carton Size O.D. W x D x H	Carton Weight	Shipping Size - cu. Ft.	Shipping Weights
Base, Legs	IWB-0	32" x 7.25" x 53.5"	74.98 lbs.	7.18	88.85 lbs.
Upper Frame	IWB-1/IWB-2	29.75" x 8.25" x 50"	51.8 lbs.	7.1	61.07 lbs.
Main Frame	IWB-3	17.5" x 12" x 35.5"	19.18 lbs.	4.31	24.1 lbs.
Short Throw PA	IWB-5	11" x 10.75" x 51.5"	22.73 lbs.	3.52	27.14 lbs.
Lock Box	IWB-7	21.75" x 5.25" x 22.5"		1.49	34.83 lbs.
Rear Whiteboard	IWB-8	25.75" x 12.25" x 45"	38.14 lbs.	8.77	69.23 lbs.
Tub Frame	IWB-9	17.5" x 4" x 21.75"	9 lbs.	0.88	11.27 lbs.
Container Box	IWB-CB	13" x 11.5" x 16"	7 lbs.	1.38	7 lbs.
Laptop Arm	IWB-LA	11" x 5.25" x 21"		1.04	10.25 lbs.

All dimensions +/- 1/2" (1.27 cm). All weights +/- 2 lbs. (0.9 kg).

Note: Interactive whiteboard(s) and/or projectors are not included with any version of our CEPART.



1.800.267.8494
www.i-rover.info
info@copernicused.com

USA
 PMB#459, 60 Industrial Pkwy
 Cheektowaga, New York 14227

Canada
 RR#3, 8194 County Rd. 109
 Arthur, Ontario NOG 1A0

Copernicus Educational Products is not responsible for printing errors. Copernicus reserves the right to change or modify pricing and products specifications with or without prior notification. Illustrations and descriptions may not be exactly as shown. No part may be reproduced by any means without prior authorization of Copernicus Educational Products Inc. All rights reserved. 2013 ©