

Tech Tub²

Model: FTT700, FTT699

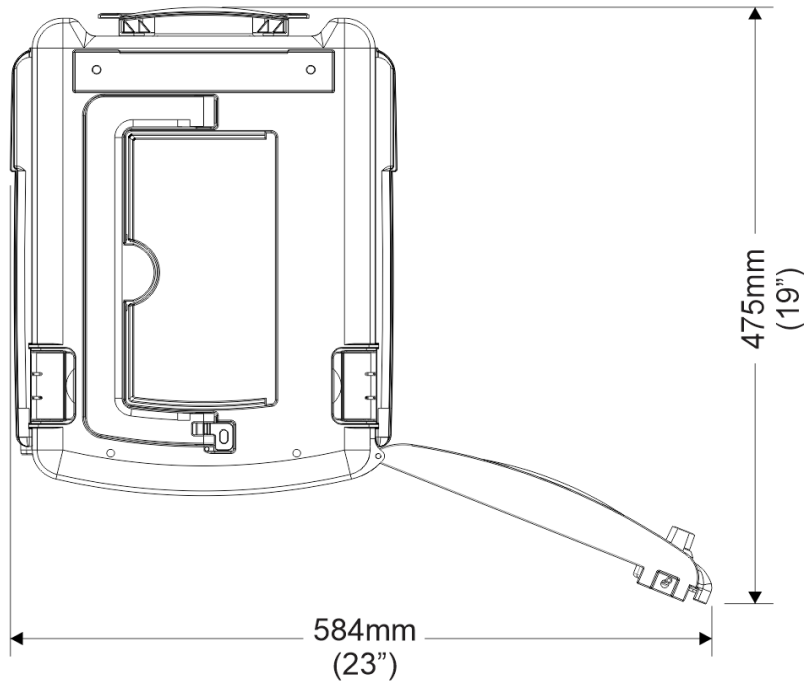
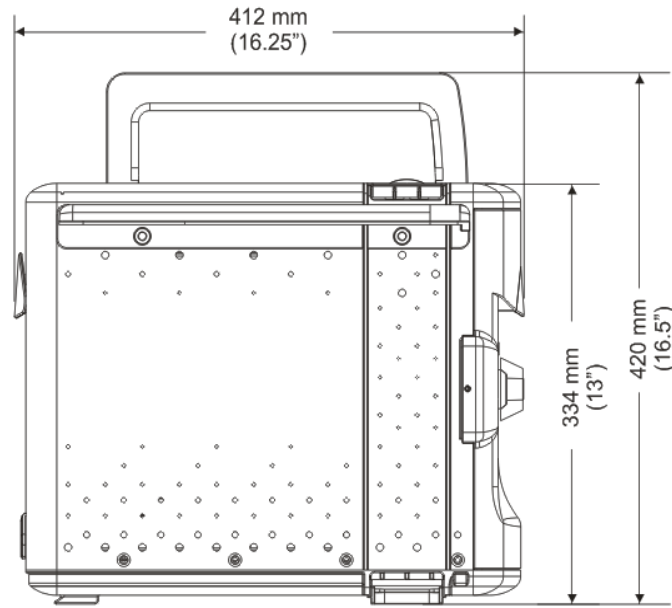
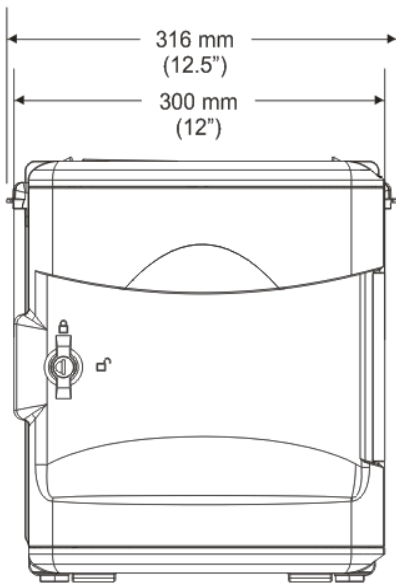

Tech Tub²®

Model: FTT700, FTT699

Warranty:

Lifetime warranty

Physical Specifications:

Door Closed, Handle Down, No Rails (Minimum Dimensions)

13-1/8" H x 11-7/8" W x 16-1/4" D (33.4cm H x 30.0cm W x 41.2cm D)

Door Open, Handle Up, With Rails (Maximum Dimensions)

16-1/2" H x 23" W x 18-3/4" D (42.0cm H x 58.4cm W x 47.5cm D)

Tech Tub²®

Model: FTT700

Carton Sizes & Weights:

	Part No.	Carton Size (outer dimensions)	Carton Weight	Shipping Size (cubic feet)	Shipping Weights (lbs)
6 device Tech Tub²® with power strip	FTT700	18" H x 12-1/2" W x 14" D 45.7cm H x 31.8cm W x 35.6cm D	15lbs 6.8kg	1.9	14

Tech Tub²®

Model: FTT699

Carton Sizes & Weights:

	Part No.	Carton Size (outer dimensions)	Carton Weight	Shipping Size (cubic feet)	Shipping Weights (lbs)
6 device Tech Tub²® with power strip - with extension cords	FTT699	18" H x 12-1/2" W x 14" D 45.7cm H x 31.8cm W x 35.6cm D	16lbs 7.295kg	1.9	14

Copernicus Educational Products

USA | P.O. Box 248 | Buffalo, NY | 14225

CANADA: R.R. #3, 8194 County Road 109 | Arthur, ON | N0G 1A0

P 1 800 267 8494 | E info@copernicused.com

Copernicus Educational Products is not responsible for printing errors. Copernicus reserves the right to change or modify pricing and products specifications with or without prior notification. Illustrations and descriptions may not be exactly as shown. No part may be reproduced by any means without prior authorization of Copernicus Educational Products Inc. All rights reserved. 2018 ©